

Cold milling machine W 500

Technical specification



Technical specification

	Cold milling machine W 500	
Milling width max.	20" 500 mm	
Milling depth*¹	6" 0–160 mm	
Milling drum		
Tool spacing	1/2" 15 mm	
Number of tools	50	
Drum diameter with tools	24" 610 mm	
Diameter of the milling drum	15" 385 mm	
Drum inclination, max.	10°	
Engine		
Manufacturer	IVECO	
Type	8045.SU 00	
Cooling	Water	
Number of cylinders	4	
Output	79 kW / 105 HP / 107 PS	
Engine speed	2,300 min ⁻¹	
Displacement	238 in³ 3,900 cm ³	
Fuel consumption, 1/1 load	5.2 gal/h 19.7 l/h	
Fuel consumption, 2/3 load	3.4 gal/h 13.0 l/h	
Speed/gradeability		
Operating speed, 1 st gear	0–66 ft/min 0–20 m/min	
Travel speed	0–4 MPH 0–6 km/h	
Theoretical gradeability in 1 st gear	60 %	
Theoretical gradeability in travel gear	60 %	
Ground clearance	8" 200 mm	
Weights *²	with conveyor	without conveyor
Front axle load, full tanks	5,512 lbs 2,500 daN (kg)	6,945 lbs 3,150 daN (kg)
Rear axle load, full tanks	11,023 lbs 5,000 daN (kg)	7,826 lbs 3,550 daN (kg)
Own weight	14,991 lbs 6,800 daN (kg)	13,228 lbs 6,000 daN (kg)
Operating weight, CE* ³	16,094 lbs 7,300 daN (kg)	14,330 lbs 6,500 daN (kg)
Operating weight, full tanks	16,535 lbs 7,500 daN (kg)	14,771 lbs 6,700 daN (kg)
Tyres		
Type	Solid rubber	
Tyre size, front (dia. x W)	22" x 10" 560 x 250 mm	
Tyre size, rear (dia. x W)	22" x 10" 560 x 250 mm	
Tank capacities		
Fuel tank	43.6 gal 165 l	
Hydraulic fluid tank	39.6 gal 150 l	
Water tank	60.8 gal 230 l	
Electrical system	24 V	
Conveyor system		
Belt width	16" 400 mm	
Theoretical conveyor capacity	65 m ³ /h	
Shipping dimensions		
Dimensions of machine (L x W x H)	11' 10" x 5' 7" x 6' 11" 3,600 x 1,700 x 2,100 mm	11' 10" x 5' 7" x 6' 11" 3,600 x 1,700 x 2,100 mm
Dimensions of conveyor (L x W x H)	19' 4" x 2' 10" x 3' 5,900 x 860 x 900 mm	–

*¹ = The maximum milling depth may deviate from the value indicated, due to tolerances and wear.

*² = All weights refer to basic machine without any additional equipment.

*³ = Weight of machine with half-full water tank, half-full fuel tank, driver (75 kg) and tools.

Technical description

Dimensions in American standard and mm

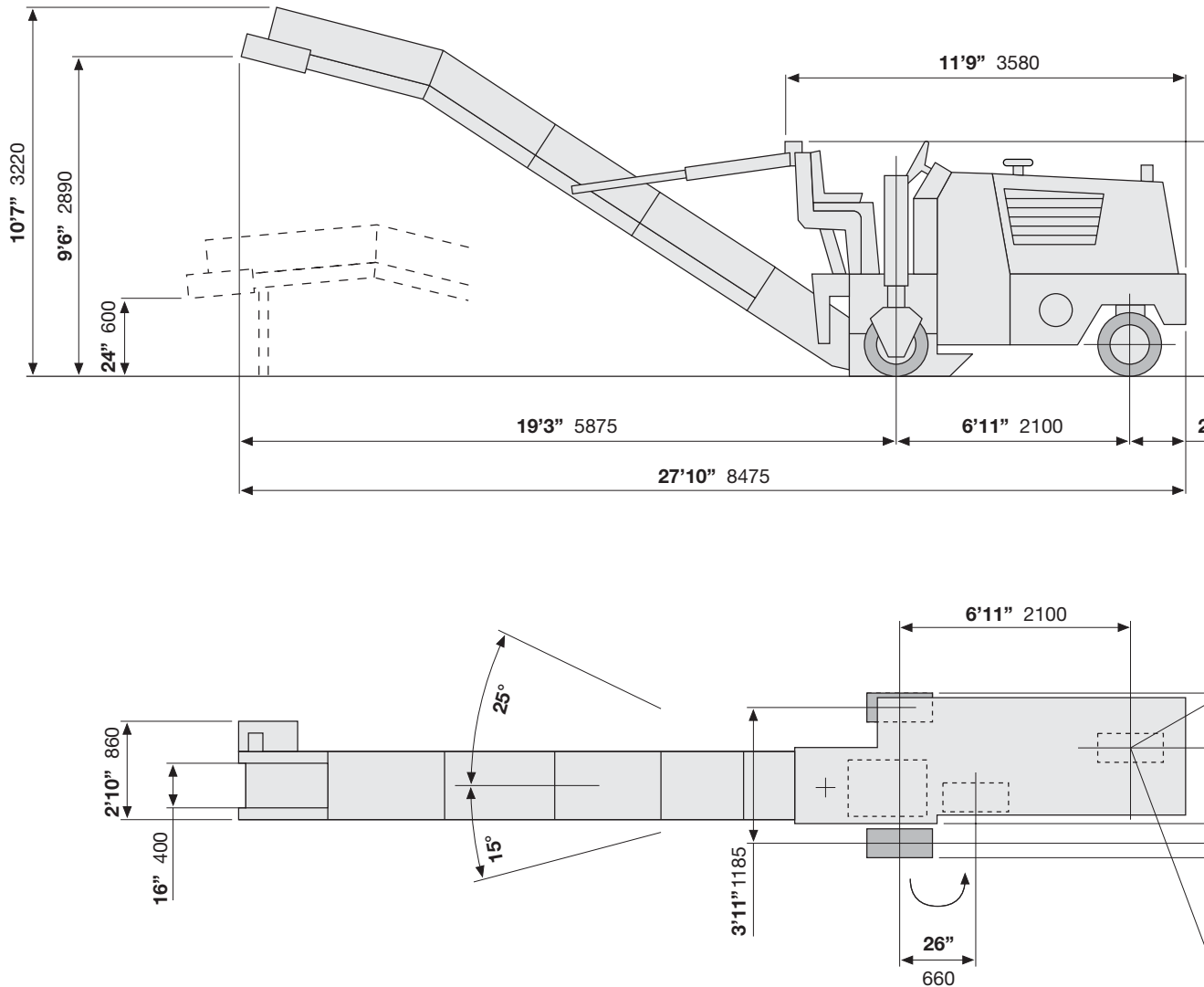

Basic design

Compact three-wheel cold milling machine with all-wheel drive, hydraulic driven milling drum and loading conveyor system.

Chassis

Robust welded design with fittings for individual components and parts as well as integrated fuel and water tanks. All components are easily accessible for fast maintenance and repair.

Suspension

The rear wheels are individually suspended. The right rear wheel can be swung in front of the milling drum for cutting flush to curbs or along other obstacles. The pivotable front wheel is connected to the chassis.

As an option the machine can be delivered as 4-wheel-machine. In this version, the single front wheel is replaced by a complete front axle.

Steering

The machine has a finger light hydraulic steering system.

Travel drive

All three wheels are individually driven by hydraulic motors which are fed by a common hydraulic variable displacement pump.

The advance speeds in milling gear and travel gear are infinitely variable.

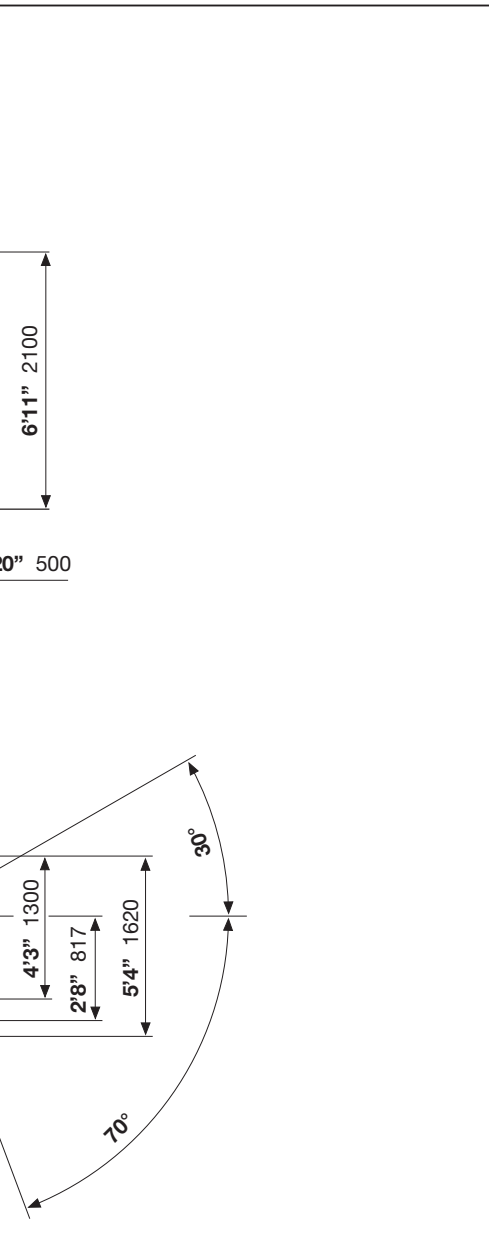

Special equipment: Version without conveyor

Dimensions in American standard and mm

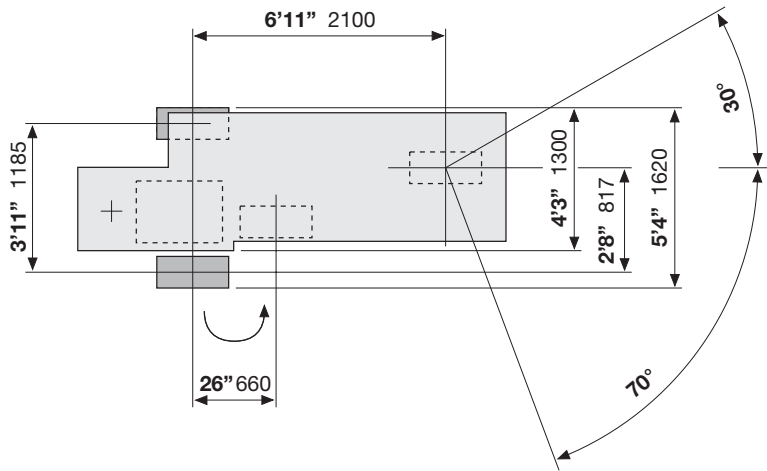
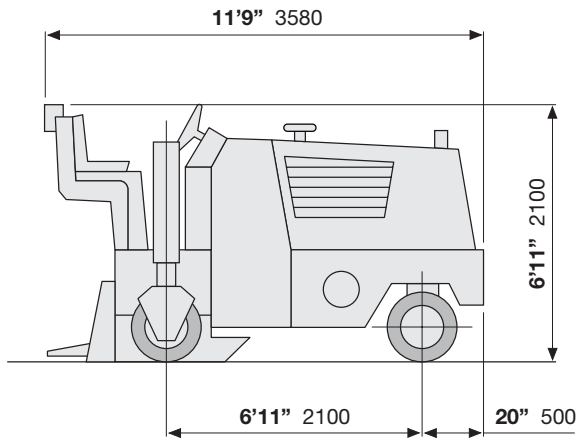

Brake system

Braking is achieved by drag from the hydrostatic transmission (closed-loop system). The hydraulic motors are in addition fitted with an automatic springloaded brake.

Milling drum

The drum is located between the rear wheels and operates in an up-milling direction. Toolholders accommodating the round-shank cutters are

welded onto the drum body. Special edge flightings ensure a clean sharp cut at the edges. For special applications a variety of milling drums and cutting wheels in various widths is available.

Tool changes

The scraper blade can be raised and lowered hydraulically in seconds to facilitate excellent access to the milling drum and cutting tools.

Milling depth adjustment

The depth adjustment is carried out via the two adjustable support wheels which are located at the rear of the machine. Adjustment is carried out hydraulically whereby differing settings permit wedge-type milling. The set milling depths can be seen on scales at the left and right hand side.

Conveyor

The hydraulically slewable and

height-adjustable conveyor accepts the milled material from the milling drum for loading into trucks.

The conveyor is covered to prevent clouds of dust being blown away by the wind and causing any nuisance.

Water spray system

The integrated water spray system will suppress the development of dust during the milling operation, cools the milling tools and reduces wear of the tools.

The spray nozzles can be easily removed to facilitate cleaning.

Soundproofing

Noise levels are reduced by the standard soundproofing which also protects both the operators and the environment against any nuisance due to noise.

Operator's stand

The clearly designed operator's stand at the rear of the machine is equipped with all controls and governing units which are easily accessible from the driver's seat.

Hydraulic system

The hydraulic systems for milling drum, travel drive, conveyor and all governing

functions operate independently. Filtering units are integrated into the system as well as an oil cooler.

Electrical system

24-Volt system with 3-phase alternator and two 12-Volt batteries, starter and electrical socket.

Safety devices

The machine is equipped with sturdy loading and lashing lugs for crane loading and securing the machine on low loader. A powerful horn, an easily accessible EMERGENCY-OFF-switch as well as a complete set of working lights ensure safe operation.

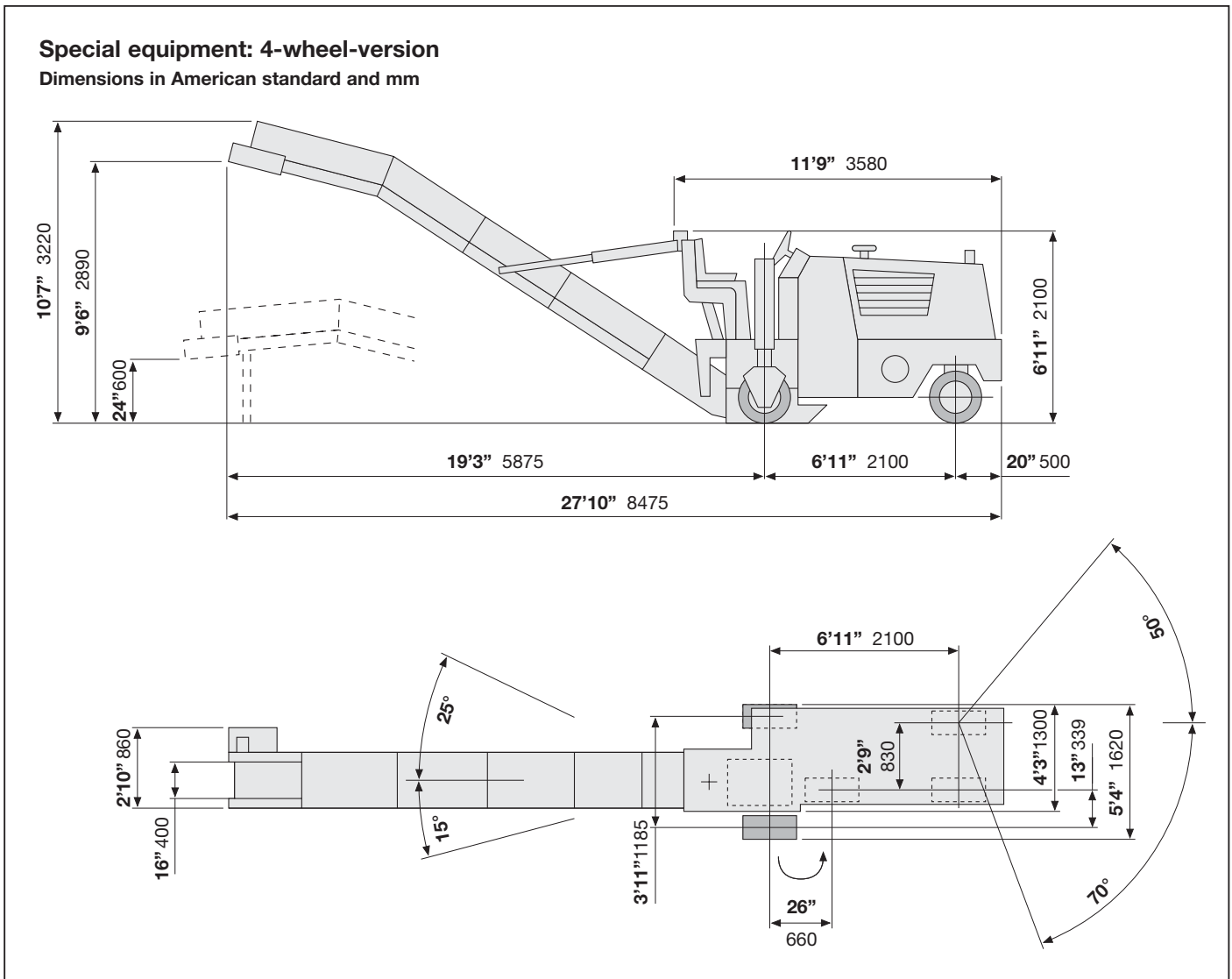

○ Serie ● Option

Equipment	Cold milling machine W 500
Transport	
Loading and lashing lugs	○
Towing device	●
Road traffic licence	●
Trailer for transporting the machine	●
Milling unit	
Loading conveyor	○
Version without loading conveyor	●
Side mounted milling wheels	●
Fine milling drums	●
Hydraulic side plate lifters	●
Machine control and level control	
Automatic levelling system right	●
Automatic levelling system left	●
Suspension and wheels	
Machine equipped with three wheels	○
Machine equipped with four wheels	●
Miscellaneous	
Comprehensive tool kit	○
Working lights	○
Warning lights	○
Reverse horn	●
Wing mirror	●
Soundproofing	○
Cyclonic precleaner for engine air filter	●
Integral soot filter	●
Hydraulic connection for additional tools	●
Hydraulic hammer	●
Special painting	●
Canopy roof	●
Operation of the cold milling machine with biodegradable hydraulic fluid	●
CE-mark	○
Comprehensive safety package with Emergency-OFF switch	○
Safety certificate by the employer's liability insurance association	○



WIRTGEN AMERICA

Wirtgen America Inc.
6030 Dana Way
Nashville, TN 37013, USA

Phone: (615) 501-0600

Fax: (615) 501-0691

Internet: www.wirtgenamerica.com